



# Tech Tip

BELTS 142

## ELIMINATING BELT NOISE Check for Factory Solutions!

**N**othing can be more frustrating to the customer than a high-pitched belt squeal or an annoying chirping sound coming from the accessory drive belt or pulleys. The first suspect is almost always the belt, and it is often replaced numerous times in a futile effort to eliminate the noise.

Troubleshooting the reason for the belt noise condition, rather than throwing parts at the symptom, is the key to eliminating a recurring belt noise complaint. Always verify the correct belt has been installed, the pulleys are in alignment and the belt is properly tensioned, prior to replacing parts. Inspect the automatic tensioner, as they wear out and must be replaced. Only in isolated cases is the solution to the noise problem determined to be a material compound issue with the belt. Switching belts or belt manufacturers is usually just a short term solution.

The technician must do his homework or else the vehicle will likely return with the same belt noise complaint. When you encounter a vehicle with a recurring belt noise condition and you have exhausted the normal troubleshooting procedures, chances are the vehicle may have a condition that is inherent by design. Check the factory service bulletins for solutions. Drive belt and pulley noise symptoms create a major warranty expense for the vehicle manufacturers, and many of them are addressing the complaints with some unique solutions. Read on to determine how creative some vehicle manufacturers get in solving those frustrating belt noise complaints.

### PCM PROGRAM UPDATE

Troubleshooting a belt noise or A/C compressor noise condition on GM's 2007–2008 Cadillac Escalade, Chevrolet Avalanche, Silverado, Suburban, Tahoe, GMC Sierra or Yukon may require a computer update.

The complaint from the customer will likely involve a noise described as a belt chirp or a thumping/grinding noise. If the A/C compressor or serpentine belt emits a noise during start-up with ambient temperatures above 95° F, GM offers a revised PCM calibration to address the condition. GM cautions not to replace the compressor, compressor clutch, serpentine belt or the belt tensioner, as replacing these components will not eliminate the noise. The noise being emitted is caused by the A/C compressor trying to move liquid refrigerant through the system. A revised program for the PCM has been developed to eliminate the belt noise condition.

### CHIRPING DODGE TURBO DIESEL

2003–2006 Dodge Ram Trucks equipped with a 5.9L turbo diesel engine may emit a chirping sound. The noise is the result of the accessory drive belt slipping on the alternator pulley during engine shutdown. This condition is not uncommon with other vehicle manufacturers' diesel applications, due to the high compression pressures and the sudden stop of the crankshaft during engine shutdown. Dodge recommends replacing the alternator pulley with a revised pulley (P/N 05183490AA), which incorporates an over-running clutch. Read on for more information concerning overrunning clutch pulleys.

### OVERRUNNING CLUTCH PULLEY

Numerous vehicle manufacturers are beginning to incorporate overrunning clutch pulleys or a similar device called an isolator de-coupler pulley (IDP) into their belt-driven components to reduce annoying belt squeal conditions. The alternator is one such component that is seeing an increased usage of these devices. You may have encountered these components when servicing Nissan, Porsche, Audi, Mazda, Mercedes, Volkswagen or Volvo vehicles. Domestic vehicle manufacturers are beginning to utilize the benefits of the overrunning clutch pulleys in their vehicles to accomplish the same.

The overrunning clutch absorbs vibrations and fluctuations in the belt drive system. Sudden changes in engine speed during deceleration, engine shutdown, or transmission gear shifts can result in belt slippage due to the alternator's internal mass and the inertia of the heavy rotor mass. Slippage can promote accelerated belt wear, noise and vibrations.

The clutch mechanism is designed to disengage the alternator (free-wheel) from the belt drive system during engine deceleration. The advantage of the clutch system is more evident on engines that encounter rapid speed changes, such as the previously mentioned turbo diesel application whose crankshaft encounters an abrupt stop during engine shutdown. This is due to the high compression characteristics of the engine. While the clutch mechanism has been popular in the heavy-duty truck market and European applications, you can expect to see the overrunning alternator clutch pulleys and similar devices become commonplace on domestic and import applications. On a conventional pulley, the belt tension is often increased to prevent belt slippage. Systems fitted with the overrunning pulleys do not require the same excessive belt

tension, as required with a conventional alternator pulley. This can minimize premature bearing failure and belt wear, due to the excessive loads.

## COLD START WHISTLE

Ford advises that the belt drive system may emit a hoot or whistle noise during start-up. Applications affected include the following vehicles equipped with a 4.6L or a 5.4L engine:

2007–2008 Mustang, Expedition, Explorer Sport Trac, Explorer and F150.

2007–2008 Lincoln Mark LT, Navigator.

2007–2008 Mercury Mountaineer

The noise condition is most evident during cold engine idle speeds at approximately 1200 RPM, with the ambient temperature at approximately 40°F. The high-pitched metallic noise will likely diminish after ten minutes of engine run-time.

To diagnose the condition, the drive belt should be removed and the engine operated momentarily, while observing for the noise condition. Absence of the noise confirms that the drive belt is the source of the noise. To eliminate the condition, Ford recommends replacing the nylon idler pulley with a revised steel pulley. The part number for the replacement pulley is 6L2Z-6C348A, with a list price of \$33.87.

## LASER PULLEY ALIGNMENT

Many belt noise problems originate due to improper pulley alignment. The component that is most often the culprit is the power steering pulley. The power steering pulley is pressed onto the pump shaft and there is little margin for error in its placement, without affecting belt alignment.

To insure proper belt alignment, GM is currently recommending the use of a laser alignment tool to establish proper pulley

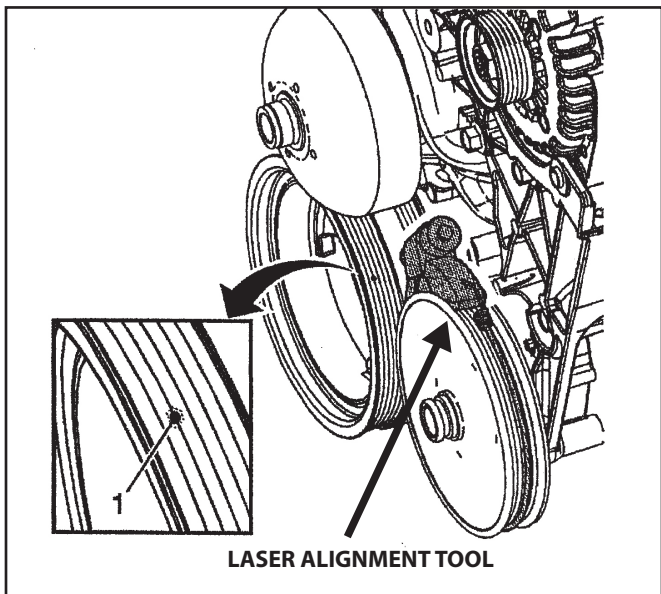

alignment on their 2009 and prior passenger cars and trucks (see illustration). GM recommends the Kent-Moore EN-49228 Laser Alignment Tool. The laser tool makes the pulley alignment process more precise, and will reduce comebacks and warranty repairs due to accelerated belt wear, slippage, and belt noise complaints. Instructions are included with the laser kit to insure proper set-up and alignment. Other tool equipment companies offer similar laser alignment tools. Make certain you follow all safety precautions including: don't look directly into the laser beam, do not shine the laser on a highly polished or reflective surface and don't point it at a fellow technician. Always use laser safety glasses when using the equipment.

## DRIVE BELT SQUEAL

Owners of Toyota Tundra trucks may encounter a squealing noise from the accessory drive belt, primarily during cold start-up. Toyota has released an improved belt tensioner and a new design A/C compressor bracket for 2000–2006 Tundra applications equipped with the 4.7L engine (2UZ-FE) produced before the production change VINs reflected below.

Type	Drivetrain	Production Change Effective VIN
B&C-Cab	4X2	5TBRT381X6S483122
	4X4	5TBBT44116S486648
D-Cab	4X2	5TBET34186S551552
	4X4	5TBDT441X6S547729

The current part number for the compressor mounting bracket is 88431-0C012. The revised tensioner is part number 16620-0W100. The allotted labor time is 3.5 hours.

2005–2006 Tundra trucks equipped with the 4.7L engine (2UZ-FE) without air conditioning get a revised idler pulley bracket (P/N 16630-50020). The idler pulley bracket replaces the A/C compressor on non-A/C equipped vehicles.

Accurately diagnosing the reason for a belt noise condition can be a challenge. The first assumption has always been directed toward the quality of the belt. Unfortunately, the solution to the problem usually involves more than a simple belt replacement. If you fail to accurately diagnose the culprit, the vehicle is certain to return with the same belt noise symptom. The customer may give you a second opportunity to fix the problem, and then out of frustration take the vehicle elsewhere to be repaired.

LARRY HAMMER  
Technical Services  
Mighty Distributing System of America



**MIGHTY: THE PMPROS**

www.mightyautoparts.com