



Tech Tip

AIR FILTERS 176

AIR FILTERS AND HOUSINGS The System Must Be Properly Sealed

Performing an air filter inspection is a key part of the vehicle inspection process. A contaminated or improperly sealed air filter can have a major impact on the performance of the engine, its longevity, or damage to costly electronic sensors.

In addition to inspecting the air filter for contamination, are you inspecting the housing and related plumbing? This is a major part of the air filtration system. Damage to the housing or the air box may result in the replacement of some expensive electronic components or a catastrophic engine or turbocharger failure.

Unfortunately, many will not take the time to inspect the air box and related housing to make certain the system is properly sealed. With a shop full of vehicles and impatient customers wanting their vehicle, it is understood why this area is often neglected. However, plastic, rubber and metal components fail and when they do, unfiltered air can enter the engine, resulting in some major expensive repairs or inaccurate sensor readings, resulting in poor engine performance. Look for evidence of damaged clamps, a deformed or cracked air box or housing, or any condition that could allow unfiltered air to enter the engine.

Examine the filter closely. Most technicians just focus on bugs and debris that can collect and restrict the filter media. They pay little attention to the filter media for evidence of water or snow contamination, which can cause major performance issues and costly engine and turbocharger damage. It is not uncommon for a turbocharged engine to pull a wet air filter or one impacted with snow completely out of the air box and partially consume it. When this happens more than an air filter is lost, as metal parts bend and break. Let's consider some filter related issues documented by the vehicle manufacturers.

DUSTING

Examine the clean air side of the air box and related housings for evidence of dust/dirt. This is often referred to as dusting. The presence of dust in these areas is an indication of filter by-pass or dust being pulled through the filter media. Dusting is not uncommon on turbocharged diesel applications, especially those operated in dusty environments such as farming, road building, oil fields, etc. Thoroughly examine the air filter seal for evidence of dust trails across the seal. This could be an indication of a damaged or distorted air box, missing clamps or broken

latches. Any missing or damaged components should be discussed with the vehicle owner and documented on the repair order, as engine damage may have already occurred.

Chrysler cautions its dealer technicians to inspect any turbo diesel engine failure for the presence of dusting. Engines damaged due to dirt/dust entering through the air intake will not be warranted. Engines that exhibit symptoms caused by improper air filter maintenance may include knocking, hard or no-start, loss of power, oil consumption, rod or main bearing failure, broken rods, excessive blow-by, oil on turbo, etc. Vehicles which exhibit large amounts of dust/dirt accumulation are candidates for dusting damage if not properly maintained, or the incorrect air filter has been installed. The following illustration provided by Chrysler reflects filter by-pass/dusting on a 6.7L turbo diesel. Damaged engines with dust/dirt on the "clean air side" of the air filter may not qualify for warranty coverage.



Look for dust/dirt on the clean air side of the filter housing

MASS AIRFLOW SENSOR

The purpose of the mass airflow sensor (MAF) is to provide a measurement of the airflow/volume and density of the incoming air to insure the proper fuel mixture for any given throttle condition. The powertrain control module (PCM) uses the MAF sensor input to calculate the

proper fuel mixture based on engine demand. The sensor readings affect the injector pulse width and engine timing requirements. Performance related symptoms including surging, stalling and transmission related symptoms may occur due to a defective or contaminated MAF sensor. Normally, a contaminated sensor will not illuminate a Check Engine light and store a trouble code, as an electrical failure with the sensor is usually required. Contamination is the leading cause of MAF sensor failure.

A damaged air inlet housing is usually the reason for a MAF sensor failure due to debris contaminating the sensor, affecting its accuracy. The contamination directly affects the fuel calibration, creating numerous driveability issues that can be difficult to diagnose. Excessively lubed aftermarket performance air filters have also been blamed for some of the performance issues due to oil/vapors contaminating the sensor, causing inaccurate readings.

The integrity of the air inlet housing/housings should be examined for splits, loose clamps, or any condition that would allow unfiltered air to enter and contaminate the MAF sensor. Dust and debris can be pulled through a heavily contaminated air filter, as previously mentioned. Keeping the system sealed and a clean air filter installed may prevent the failure of a costly MAF sensor.

The following illustration from Ford reflects a damaged throttle body air inlet housing. In addition to allowing unfiltered air to enter the engine resulting in major engine damage, the un-metered air (bypassing the MAF sensor) causes engine performance related issues.

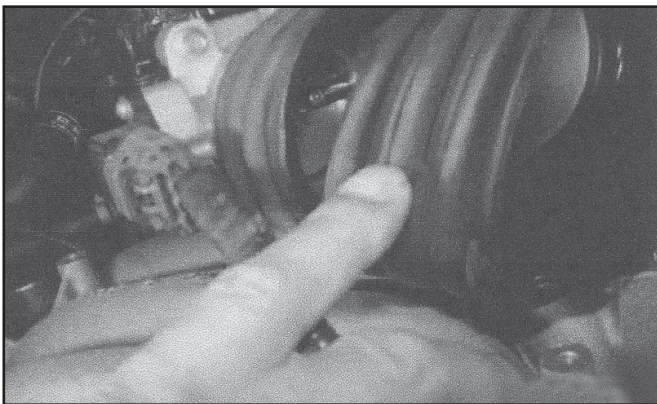

FORD MAF HOUSING

AIR FILTER COVER INSTALLATION PRECAUTION

GM has posted a service bulletin concerning the proper installation procedure to follow when installing the air filter cover onto the housing on the following vehicles:

2004–2007 Cadillac CTS (Excluding V Series)

2004–2009 Cadillac SRX

2004–2011 Cadillac STS (Except V Series)

The article cautions the installer that the air cleaner outlet side may be difficult to reinstall in the proper position if it has been fully removed from the housing. The tabs on the cover must be aligned with the slots in the housing. GM advises that it is possible to incorrectly attach the cover to the housing without the cover being properly seated (see following GM Illustration).

The incorrect installation may not be visible when viewing from the top of the housing. This condition results in unfiltered air entering the engine. When replacing the filter element, the cover does not require complete removal from the housing. The cover will pivot, allowing sufficient room to make the filter installation.

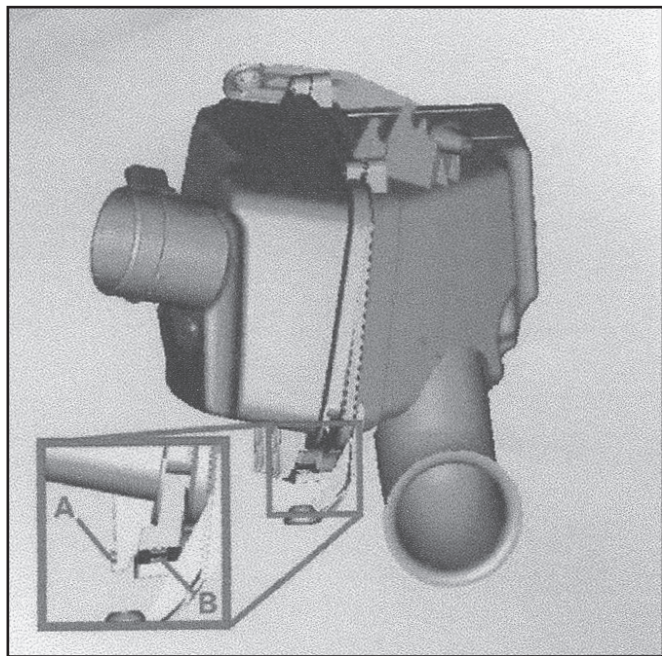

GM AIR FILTER COVER

Tabs must align with slots

Summary: Other vehicle applications share similar experiences when it comes to the proper sealing of the filter to the air box. Heat related distortion of the air box is common with taxis, police vehicles, emergency vehicles, or vehicles driven in heavily congested areas with a lot of stop and go traffic. Make a full evaluation of the air filter and related housings a part of your vehicle inspection.

LARRY HAMMER, Technical Services
Mighty Distributing System of America



MIGHTY: THE PMPROS www.mightyautoparts.com